

CLM3617

AC/DC Digital Power Controller for High Power Factor Dimmable LED Drivers

1 Description

The CLM3617 is a two-stage, high-performance AC/DC offline power supply controller for dimmable LED luminaires. It applies advanced digital control technology to detect the dimmer type and phase, which provides dynamic impedance to interface the dimmer and control the LED brightness at the same time. The CLM3617 uses unique digital technology to eliminate visible flicker in the entire dimming range and minimize low frequency output ripple current.

With advanced dimmer detection technology, the CLM3617 can operate with most wall dimmers including leading-edge dimmers (R-type or R-L type) and trailing-edge dimmers (R-C type). In addition, the CLM3617's cycle-by-cycle waveform analysis technology allows fast dimmer setting response. When no dimmer is on the line, the CLM3617 optimizes the power factor and minimizes the current harmonic distortion to the AC line.

The CLM3617 operates the main power converter that delivers constant current to the LED load in quasi-resonant mode to provide high power efficiency and minimize electro-magnetic interference (EMI). It uses patented primary-side sensing technology to achieve excellent LED current regulation under different AC line and LED load voltages, without using a secondary-side feedback circuit and eliminating the need for an optocoupler.

The CLM3617 minimizes the external components count by simplifying the EMI filter with technology. The intelligent dimmer detection technology eliminates the need for a high-power bleeder. Additionally, the digital control loop of the CLM3617 maintains stable overall operating conditions without the need for loop compensation components.

2 Features

- Isolated/non-isolated offline 120V_{AC}/230V_{AC} LED driver up to 25W output power
- Wide line frequency ranges (from 45Hz to 66Hz)
- Meets IEC61000-3-2 requirement
- Total harmonic distortion < 15% with PF > 0.95
- Wide dimmer compatibility
 - » Leading-edge dimmer
 - » Trailing-edge dimmer
 - » Digital dimmer
 - » Occupancy sensors and timers
- Under 20% output ripple current
- Wide dimming range from 1% to 100%
- **Flickerless**[™] LED dimming
- Resonant control to achieve high efficiency (typical > 85% without dimmer)
- Over-temperature LED current foldback
- Small solution size
 - » Two-stage topology enables small-size input and output filter capacitors
 - » 200kHz maximum switching frequency enables small transformer
- » Intelligent dimmer interface eliminates dedicated high-power bleeder
- primary-side sensing eliminates the need for optocoupler feedback
- Tight LED current regulation (± 5%)
- Fast start-up (< 0.5s without dimmer)
- Supports hot-plug LED module (Zhaga)
- Compatible with NEMA SSL6 dimming curve standard
- Supports wide LED output voltage range
- Multiple protection features:
 - » LED open-circuit and short-circuit protection
 - » Over-current and over-temperature protection
 - » Current sense resistor short-circuit protection
 - » AC line over-voltage/-frequency protection

3 Applications

- Dimmable LED retrofit lamps up to 25W
- Dimmable LED ballast and luminaires up to 25W

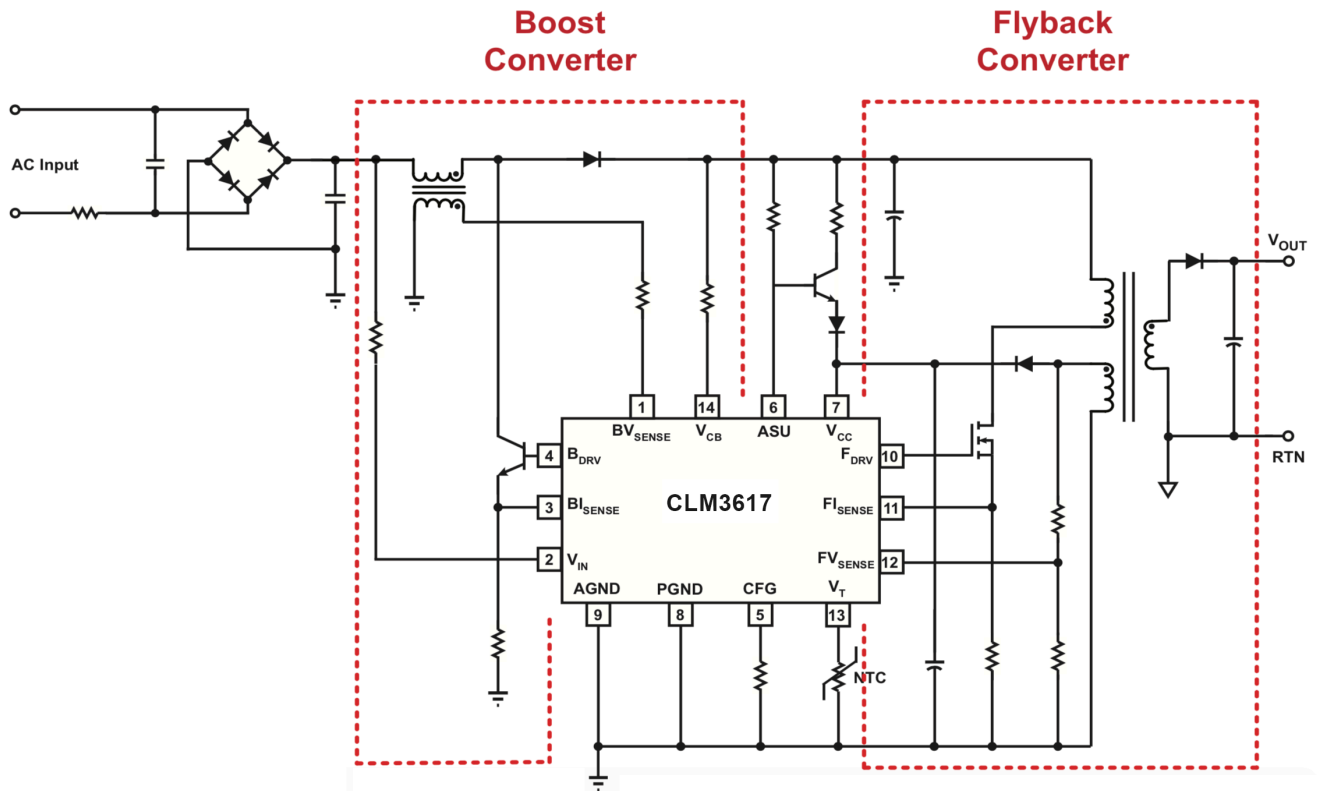

Figure 3.1 : CLM3617 Simplified Schematic

4 Pinout Description

CLM3617

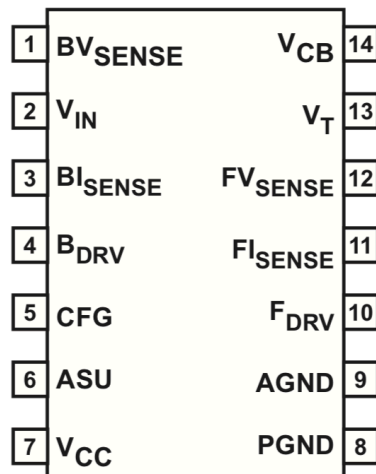

Figure 4.1 : 14-Lead SOIC Package

Pin Number	Pin Name	Type	Pin Description
1	BV _{SENSE}	Analog Input	Boost inductor voltage feedback input
2	V _{IN}	Analog Input	Rectified AC line voltage input
3	BI _{SENSE}	Analog Input	Boost current sense input
4	B _{DRV}	Output	Base drive output for boost BJT
5	CFG	Analog In/Out	Driver parameter configuration pin and auxiliary driver
6	ASU	Output	Active start-up and bleeder control
7	V _{CC}	Power	Power supply for control logic and voltage sense for power-on reset circuit. A decoupling capacitor of 0.1μF or so should be connected
8	PGND	Ground	Power ground
9	AGND	Ground	Signal ground. It should be connected to the power ground on PCB.
10	F _{DRV}	Output	Gate drive output for flyback MOSFET
11	FI _{SENSE}	Analog Input	Flyback current sense (used for cycle-by-cycle peak current control and limit)
12	FV _{SENSE}	Analog Input	Flyback voltage sense (used for primary-side regulation and ZVS)
13	V _T	Analog Input	External power limit shutdown control and external over-temperature power derating
14	V _{CB}	Analog Input	Boost output voltage feedback input

5 Absolute Maximum Ratings

Absolute maximum ratings are the parameter values or ranges which can cause permanent damage if exceeded. For maximum safe operating conditions, refer to Electrical Characteristics in Section 6.

Parameter	Symbol	Value	Units
DC supply voltage range (pin 7)	V_{CC}	-0.3 to 18	V
F _{DRV} output (pin 10)		-0.3 to 18	V
B _{DRV} output (pin 4)		-0.3 to 4.0	V
CFG input (pin 5)		-0.3 to 4.0	V
CFG output (pin 5)		-0.3 to 18	V
FV _{SENSE} input (pin 12, I ≤ 10mA)		-0.7 to 4.0	V
BV _{SENSE} input (pin 1, I ≤ 3mA)		-0.7 to 4.0	V
V _{IN} input (pin 2)		-0.3 to 18	V
V _{CB} input (pin 14)		-0.3 to 18	V
FI _{SENSE} input (pin 11)		-0.3 to 4.0	V
BI _{SENSE} input (pin 3)		-0.3 to 4.0	V
ASU output (pin 6)		-0.3 to 18	V
V _T input (pin 13)		-0.3 to 4.0	V
Maximum junction temperature	T_{JMAX}	150	°C
Operating junction temperature	T_{JOPT}	-40 to 150	°C
Storage temperature	T_{STG}	-65 to 150	°C
Thermal Resistance Junction-to-PCB Board Surface Temperature	Ψ_{JB}	45	°C/W
ESD rating per JEDEC JESD22-A114		±2,000	V
Latch-up test per JESD78A		±100	mA

6 Physical Dimensions

14-Lead SOIC Package

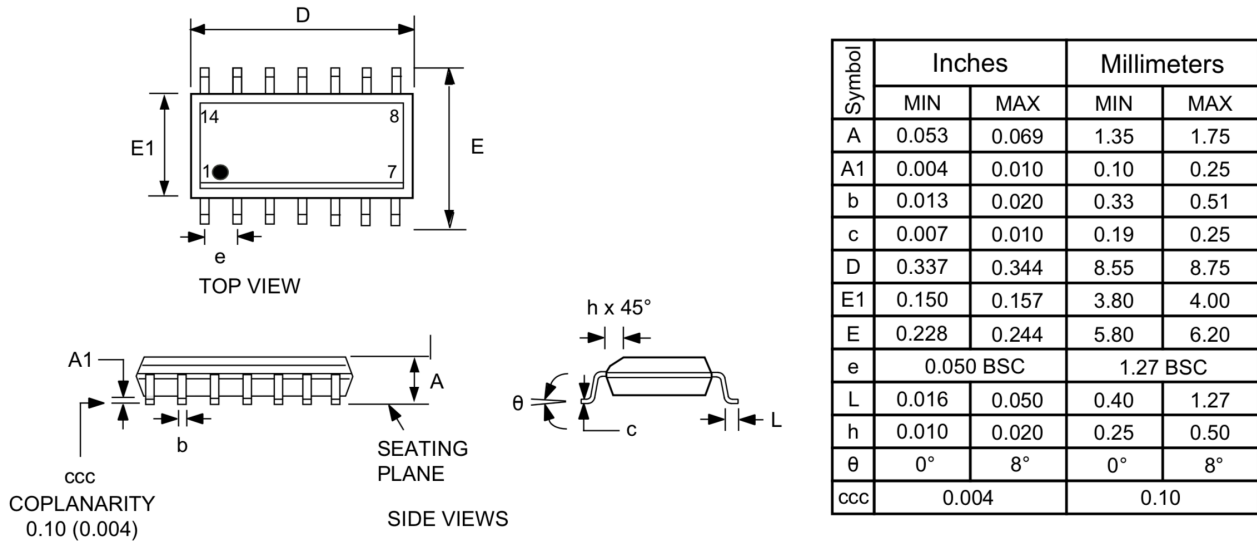

Compliant to JEDEC Standard MS12F

Controlling dimensions are in inches; millimeter dimensions are for reference only

This product is RoHS compliant and Halide free.

Soldering Temperature Resistance:

[a] Package is IPC/JEDEC Std 020D Moisture Sensitivity Level 1

[b] Package exceeds JEDEC Std No. 22-A111 for Solder Immersion Resistance; package can withstand 10 s immersion < 260°C

Dimension D does not include mold flash, protrusions or gate burrs. Mold flash, protrusions or gate burrs shall not exceed 0.15 mm per end. Dimension E does not include interlead flash or protrusion. Interlead flash or protrusion shall not exceed 0.25 mm per side.

The package top may be smaller than the package bottom. Dimensions D and E are determined at the outermost extremes of the plastic body exclusive of mold flash, tie bar burrs, gate burrs and interlead flash, but including any mismatch between the top and bottom of the plastic body.

Figure 6.1 : 14-Lead SOIC Package

7 Ordering Information

Part no.	Options	Package	Description
CLM3617-00	120V _{AC} Input	SOIC-14	Tape & Reel ¹
CLM3617-01	230V _{AC} Input	SOIC-14	Tape & Reel ¹

Note 1: Tape & Reel packing quantity is 2,500/reel. Minimum ordering quantity is 2,500.