

---

## CLM3630

### AC/DC Digital Power Controller for High Power Factor Dimmable LED Drivers

#### 1 Description

The CLM3630 is a two-stage, high-performance AC/DC offline power supply controller for dimmable LED luminaires with dimming interface. It controls LED current based on input voltage on the dimming pin. It has a

built-in 0-10V dimming interface that works directly with 0-10V dimming systems, eliminating the need for a driver circuit and microcontroller. It also provides a PWM digital interface to support wireless SSL applications, without adding auxiliary power supplies. The CLM3630 uses unique digital technology to eliminate visible flicker in the entire dimming range and to minimize low frequency output ripple current.

The CLM3630 operates the main power converter that delivers constant current to the LED load in quasi-resonant mode to provide high power efficiency and minimize electro-magnetic interference (EMI). It uses patented primary-side sensing technology to achieve excellent LED current regulation under different AC line and LED load voltages, without using a secondary-side feedback circuit and eliminating the need for an optocoupler.

The CLM3630 minimizes the external components count by simplifying the EMI filter with technology. Additionally, the digital control loop of the CLM3630 maintains stability over all operating conditions without the need for loop compensation components.

#### 2 Features

- Isolated/non-isolated offline 100V<sub>AC</sub>/277V<sub>AC</sub> LED driver controller
  - » Two-stage topology enables small-size input and output filter capacitors
  - » 200kHz maximum switching frequency enables small transformer
- Meets IEC61000-3-2 requirement
- Total harmonic distortion < 15% with Power Factor > 0.95
- input dimming level control
- Built-in 0-10V isolation transformer driver
- PWM digital interface
- Under 10% output ripple current
- Wide dimming range from 1% to 100%
- LED dimming technology
- Quasi-resonant control to achieve high efficiency (typical > 85%)
- primary-side sensing technology eliminates opto-isolator and simplifies design
- Tight LED current regulation
- Supports wide LED output voltage range
- Multiple protection features:
  - » LED open-circuit and short-circuit protection
  - » Over-current protection
  - » Current sense resistor short-circuit protection
  - » AC line over-voltage/-frequency protection
  - » Internal junction temperature-based over-temperature protection

#### 3 Applications

- Dimmable LED ballast with input for dimming control
- Dimmable LED ballast with 0-10V interface for dimming control
- Wireless SSL lighting
- Output power up to 45W
- Small size

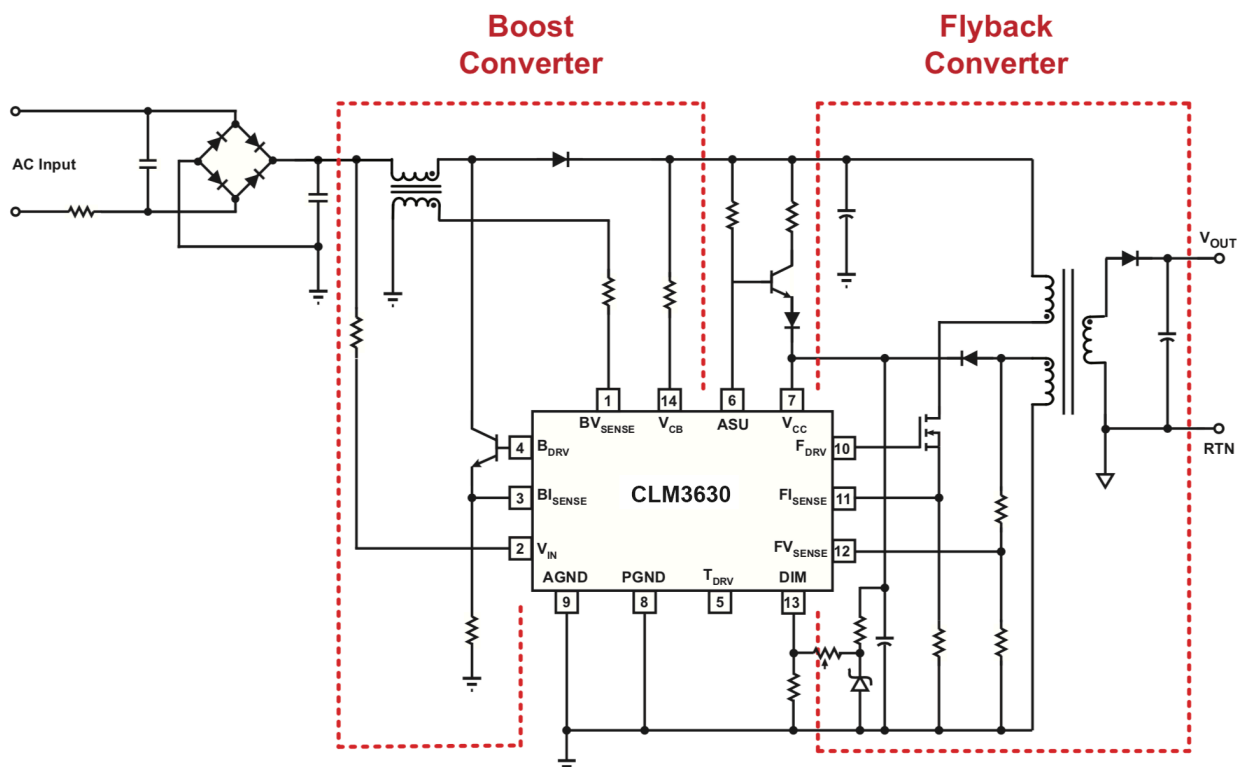
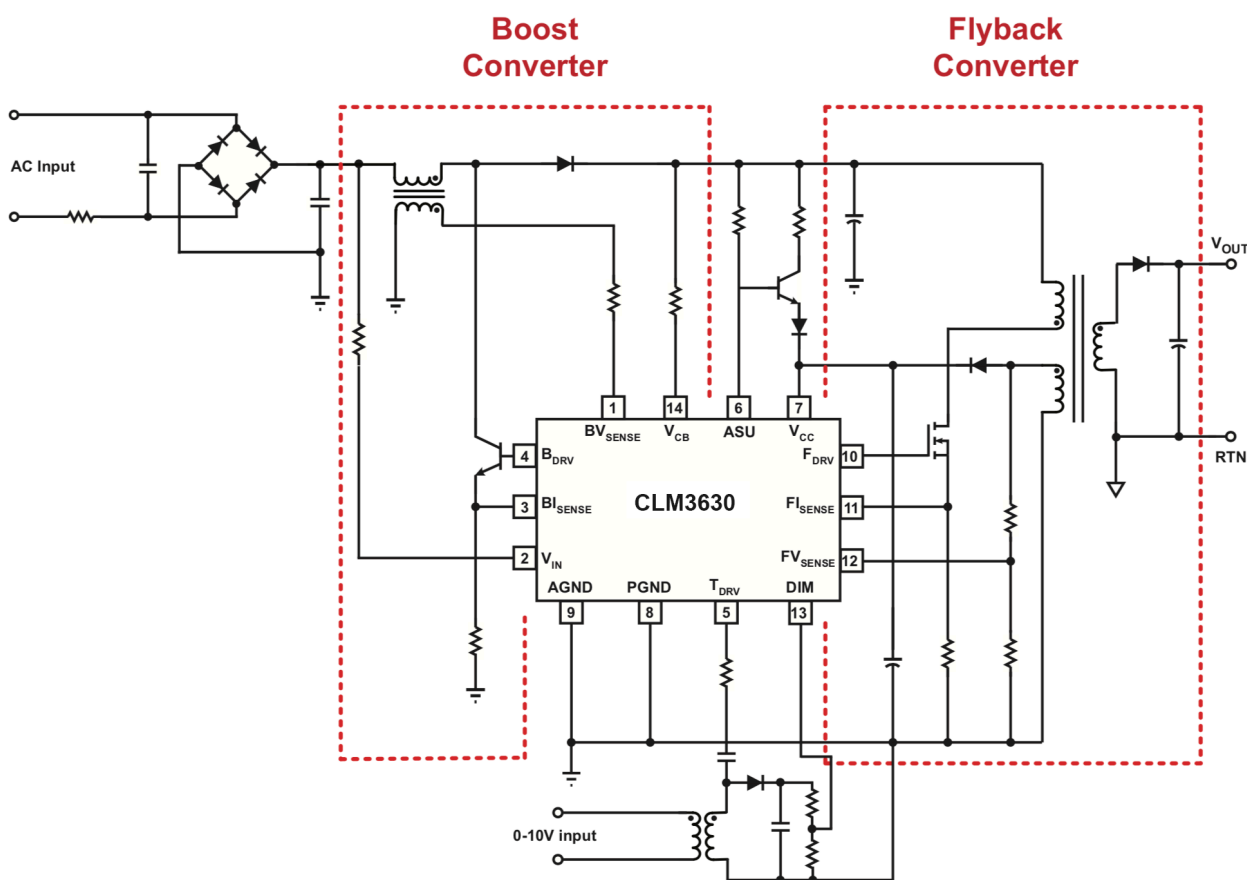

Figure 3.1 : CLM3630 Dimming Simplified Schematic



3.2 : CLM3630 0-10V Dimming Simplified Schematic

Figure

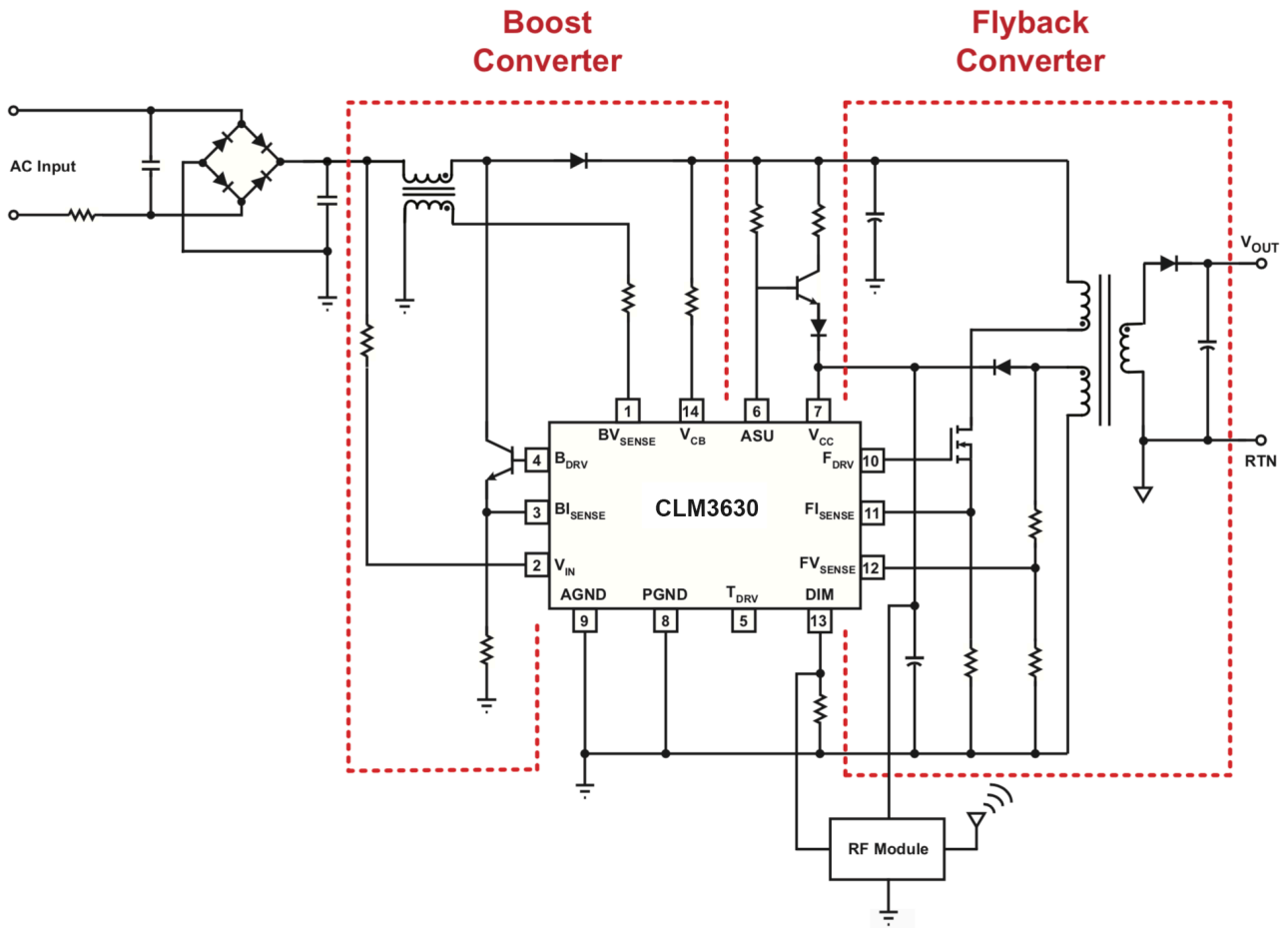

Figure 3.3 : CLM3630 Wireless Dimming Simplified Schematic

## 4 Pinout Description

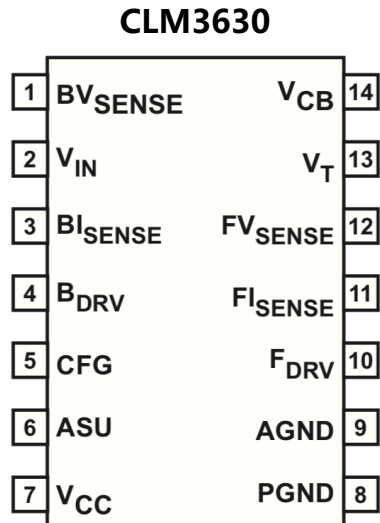

Figure 4.1 : 14-Lead SOIC Package

Pin Number	Pin Name	Type	Pin Description
1	BV <sub>SENSE</sub>	Analog Input	Boost inductor voltage feedback input
2	V <sub>IN</sub>	Analog Input	Rectified AC line voltage input
3	BI <sub>SENSE</sub>	Analog Input	Boost current sense input
4	B <sub>DRV</sub>	Output	Base drive output for boost BJT
5	T <sub>DRV</sub>	Output	0-10V isolation transformer drive output
6	ASU	Output	Active start-up and bleeder control
7	V <sub>CC</sub>	Power	Power supply for control logic and voltage sense for power-on reset circuit
8	PGND	Ground	Power ground
9	AGND	Ground	Signal ground. It should be connected to the power ground on PCB.
10	F <sub>DRV</sub>	Output	Gate drive output for flyback MOSFET
11	FI <sub>SENSE</sub>	Analog Input	Flyback current sense (used for cycle-by-cycle peak current control and limit)
12	FV <sub>SENSE</sub>	Analog Input	Flyback voltage sense (used for primary-side regulation and ZVS)
13	DIM	Analog Input	Dimming level control input
14	V <sub>CB</sub>	Analog Input	Boost output voltage feedback input

## 5 Absolute Maximum Ratings

Absolute maximum ratings are the parameter values or ranges which can cause permanent damage if exceeded.

Parameter	Symbol	Value	Units
DC supply voltage range (pin 7)	$V_{CC}$	-0.3 to 18	V
F <sub>DRV</sub> output (pin 10)		-0.3 to 18	V
B <sub>DRV</sub> output (pin 4)		-0.3 to 4.0	V
T <sub>DRV</sub> output (pin 5)		-0.3 to 18	V
F <sub>VSENSE</sub> input (pin 12, I <sub>FVSENSE</sub> ≤ 10mA)		-0.7 to 4.0	V
B <sub>VSENSE</sub> input (pin 1, I <sub>BVSENSE</sub> ≤ 3mA)		-0.7 to 4.0	V
V <sub>IN</sub> input (pin 2)		-0.3 to 18	V
V <sub>CB</sub> input (pin 14)		-0.3 to 18	V
F <sub>ISENSE</sub> input (pin 11)		-0.3 to 4.0	V
B <sub>ISENSE</sub> input (pin 3)		-0.3 to 4.0	V
ASU output (pin 6)		-0.3 to 18	V
DIM input (pin 13)		-0.3 to 4.0	V
Power dissipation at T <sub>A</sub> ≤ 25°C		900	mW
Maximum junction temperature	T <sub>JMAX</sub>	150	°C
Storage temperature	T <sub>STG</sub>	-65 to 150	°C
Thermal Resistance Junction-to-PCB Board Surface Temperature	ψ <sub>JB</sub>	45	°C/W
ESD rating per JEDEC JESD22-A114		±2,000	V
Latch-up test per JEDEC 78		±100	mA

## 6 Physical Dimensions

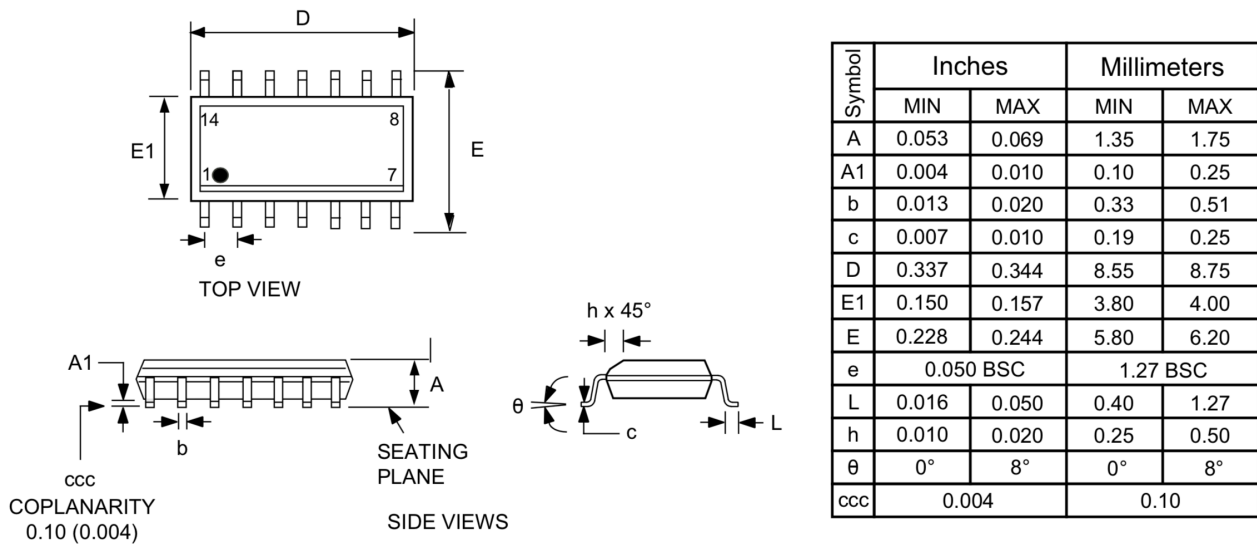

Compliant to JEDEC Standard MS12F

Controlling dimensions are in inches; millimeter dimensions are for reference only

This product is RoHS compliant and Halide free.

Soldering Temperature Resistance:

[a] Package is IPC/JEDEC Std 020D Moisture Sensitivity Level 1

[b] Package exceeds JEDEC Std No. 22-A111 for Solder Immersion Resistance; package can withstand 10 s immersion < 260°C

Dimension D does not include mold flash, protrusions or gate burrs. Mold flash, protrusions or gate burrs shall not exceed 0.15 mm per end. Dimension E does not include interlead flash or protrusion. Interlead flash or protrusion shall not exceed 0.25 mm per side.

The package top may be smaller than the package bottom. Dimensions D and E are determined at the outermost extremes of the plastic body exclusive of mold flash, tie bar burrs, gate burrs and interlead flash, but including any mismatch between the top and bottom of the plastic body.

Figure 6.1 : 14-Lead SOIC Package

## 7 Ordering Information

Part no.	Options	Package	Description
CLM3630-00	Universal input, 0-10V dimmable	SOIC-14	Tape & Reel <sup>1</sup>

Note 1: Tape and reel packing quantity is 2,500/reel.